

# Accessories

---

	Page
● Inlet Strainers, OFS	R 2
● Return Line Filters, OFR	R 3
● Air Bleed Valves, ABT	R 5
● Gauge Cock, GT	R 6
● Oil Level Indicators	
With Thermometer, OLG	R 7
● Mini-Fan Coolers, MF	R 8

# Inlet strainers OFS



Functional Symbol

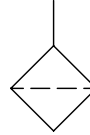

- The OFS inlet strainer is installed on the pump suction side inside tank. It prevents ingress of foreign particles to protect pump.

## Model Code

**OFS - 06 - JA - 10 - J**

1 2 3

- 1 Inlet strainer
- 2 Size  
See 'Specifications'
- 3 Design no.

## Specifications

Model	Port Dia. Rc	Rated Flow L/min	Filtration $\mu\text{m}$	Weight kg
OFS-06	3/4	35	150	0.2
OFS-08	1	60		0.4
OFS-10	1-1/4	90		0.6
OFS-12	1-1/2	140		0.8
OFS-16	2	240		1.3

## Performance Curves

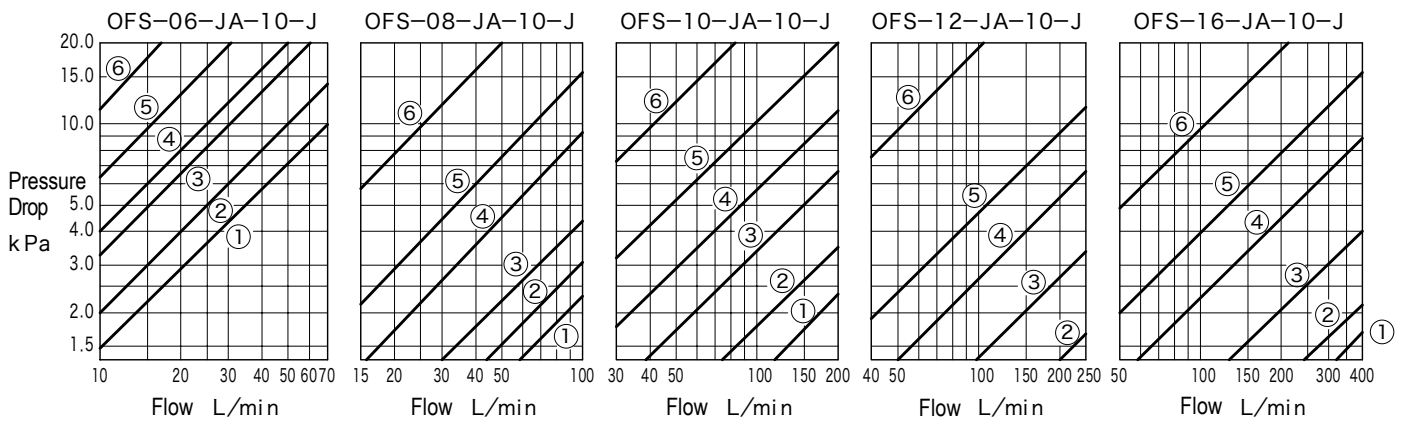

## Dimensions

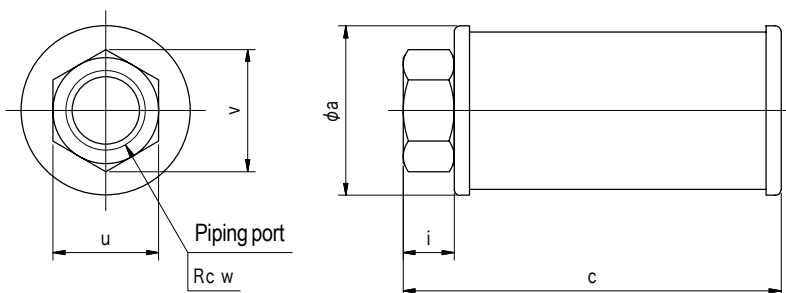

Dimensions

Model	a	c	i	u	v	w
OFS-06	56	125	17	35 <sup>0</sup> <sub>-0.35</sub>	40.4	3/4
OFS-08	80	190	19	46 <sup>0</sup> <sub>-0.4</sub>	53.1	1
OFS-10	100	233	23	58 <sup>0</sup> <sub>-0.5</sub>	67.0	1-1/4
OFS-12	119	258	25	63 <sup>0</sup> <sub>-0.6</sub>	72.7	1-1/2
OFS-16	147	333	30	77 <sup>0</sup> <sub>-0.7</sub>	88.9	2

# Return line filters OFR



Functional Symbol

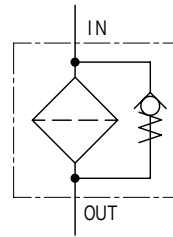

- The OFR is used in the return line of hydraulic systems. A bypass valve is incorporated in the OFR which is actuated to bypass flow when the pressure drop increases.

## Model Code

### OFR - 08 F - 10

1 2 3 4

- 1 Return line filter
- 2 Size  
See 'Specifications'
- 3 Connection  
F: Flange connection

- 4 Filtration level  
10:10  $\mu\text{m}$   
25:25  $\mu\text{m}$

## Specifications

Model	Size	Max. Inlet Pressure MPa	Rated Flow L/min	Bypass Valve Cracking Pressure MPa	Weight kg
OFR-08	1	1.5	80	0.06 ※	2.7
OFR-12	1-1/2		200		6

※: Values at rated flow.

## Performance Curves

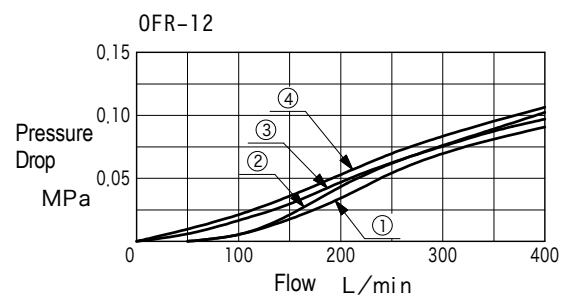
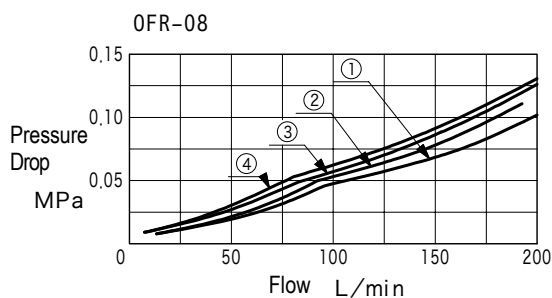

- ① Viscosity 22  $\text{mm}^2/\text{s}$ , filtration level 25  $\mu\text{m}$
- ② Viscosity 22  $\text{mm}^2/\text{s}$ , filtration level 10  $\mu\text{m}$
- ③ Viscosity 68  $\text{mm}^2/\text{s}$ , filtration level 25  $\mu\text{m}$
- ④ Viscosity 68  $\text{mm}^2/\text{s}$ , filtration level 10  $\mu\text{m}$

## Operating Considerations

- Confirm IN, OUT connections when piping. Pipe directly to tank to avoid back pressure at the OUT port.
- When filter cartridge is replaced, mount drain port toward bottom as contaminated oil may be discharged.
- Filter cannot be used with water glycol fluid.

## Dimensions

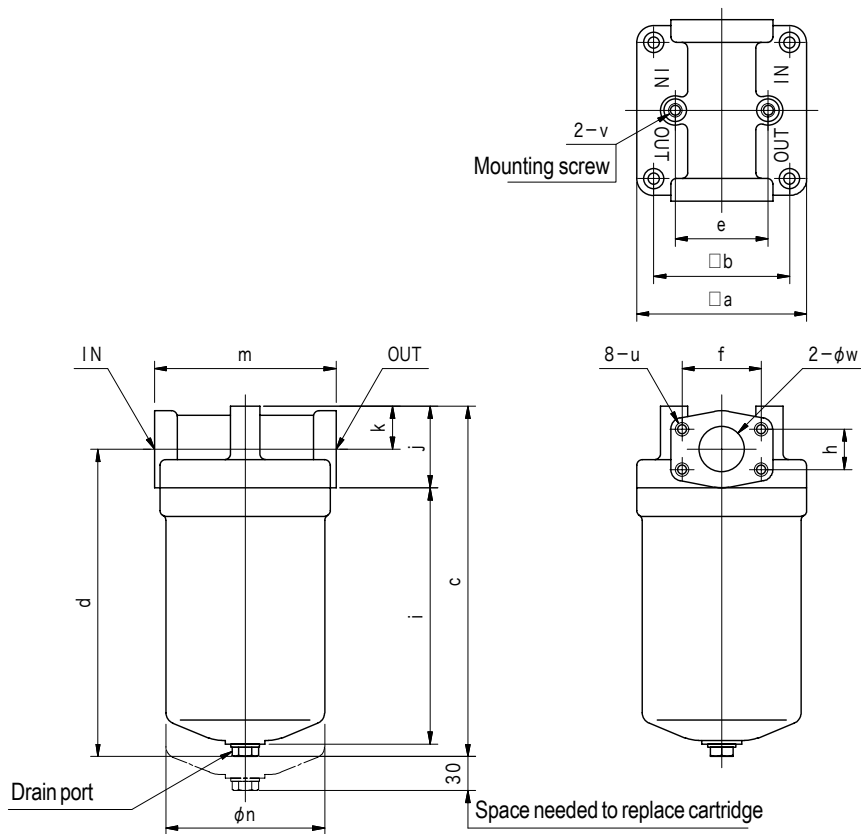

### Dimensions

Model	w	a	b	c	d	e	f	h	i	j	k	m	n	u	v
OFR-08	28	120	95	229	197	60	52.4	26.2	156	64	32	128	106	M10 20deep	M10 20deep
OFR-12	40	150	120	309	271	82	69.9	35.7	226	72	38	160	140	M12x1.25 24 deep	M12x1.25 24 deep

## Piping Flange

Filter Model	Flange Model	
	Threaded	Welded
OFR-08	FL1-8-08P-10-JA-S4-J	FL1-8-08W-10-JA
OFR-12	FL1-12-12P-10-JA-S4-J	FL1-12-12W-10-JA

- Flange mounting bolts (M10 for OFR-08, M12 X 12.25 for OFR-12) are supplied separately.
- Flanges are not included with filter unit.

# Air bleed valves ABT

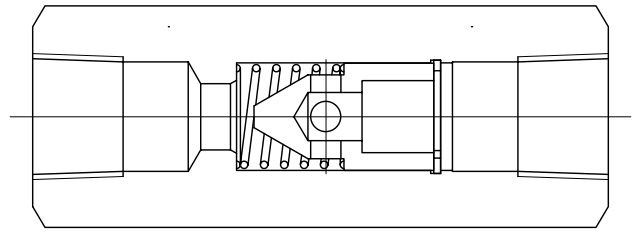

Functional Symbol

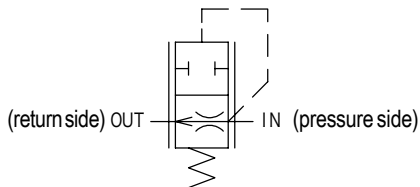

- The ABT valve enables bleeding of air from hydraulic circuits.
- The valve closes when circuit pressure exceeds 0.14MPa.

## Model Code

**ABT - 03 - 10 - JA - (S4) - J**

1      2      3      4

- 1 Air bleed valve
  - 2 Size
  - 3 Design no.
  - 4 Special suffix
- Omitted for 11 L/min min. flow to close valve  
S4: 0.3 L/min min. flow to close valve

## Specifications

Max. operating pressure :21MPa  
Weight :0.2kg

## Operating Considerations

- Valve should be located at highest position in circuit and mounted vertically.
- Return line should be connected directly to tank and piped below oil level.
- As valve is not a no-leak valve, always incorporate a return line.

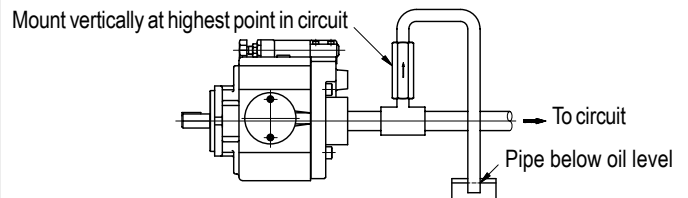

## Dimensions

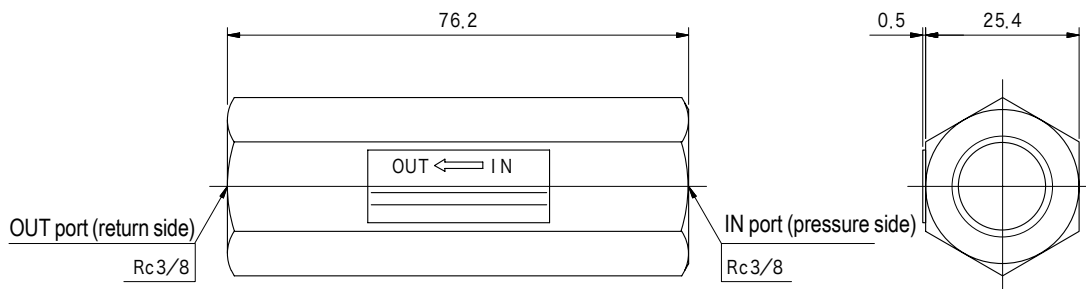

# Gauge cock GT



Functional Symbol

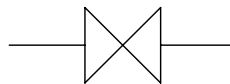

## Model Code

### GT-3 (M)

1 2 3

1 Gauge cock

2 Pressure gauge port diameter

2:G1/4

3:G3/8

4:G1/2

3 Port connection

Omitted for female thread, Rc 1/4

Male thread R 1/4 (for GR-3M, GT-4M)

## Specifications

Max. operating pressure: 28MPa

## Dimensions

GT-2  
GT-3  
GT-4

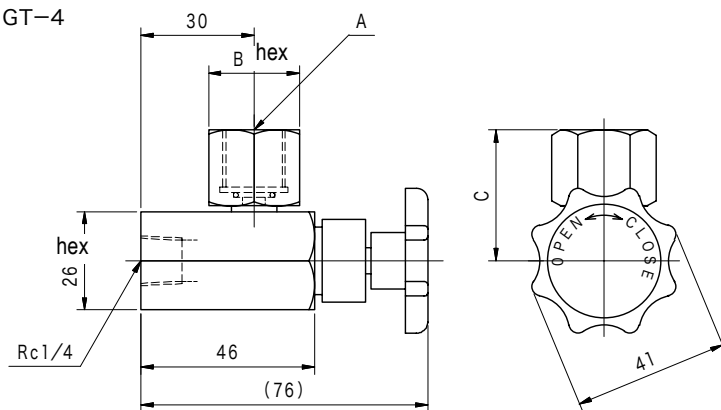

GT-3M  
GT-4M

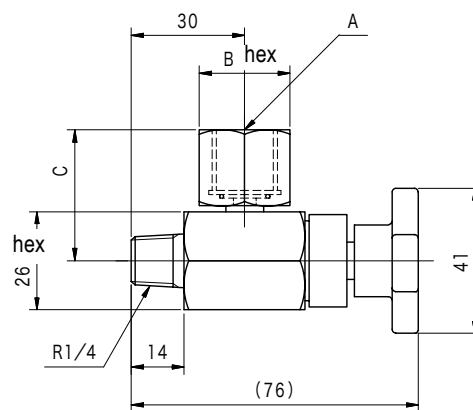

Dimensions

Model	Description	A	B	C
GT-2	1/4 Gauge cock	G1/4	21	34.5
GT-3	3/8 Gauge cock	G3/8	24	34.5
GT-4	1/2 Gauge cock	G1/2	29	37.5

Dimensions

Model	Description	A	B	C
GT-3M	3/8 Gauge cock	G3/8	24	34.5
GT-4M	1/2 Gauge cock	G1/2	29	37.5

# Oil level indicators with thermometer OLG T



Functional Symbols

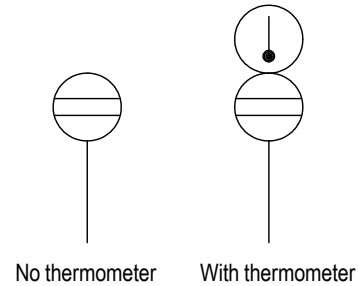

## Model Code

### OLGT 2 - 100

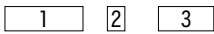

- 1 Oil level indicator  
OLG:No thermometer  
OLGT:With thermometer
- 2 Indicator marks  
1:1 (H position only)  
2:2 (H and L positions)
- 3 Mounting bolt center distance  
100:100mm  
200:200mm

## Specifications

Material: acrylic resin  
 Endurance temperature :85°C  
 Temperature scale : 0°C~ +100  
 Mounting bolt tightening torque:17~19N·m

## Dimensions

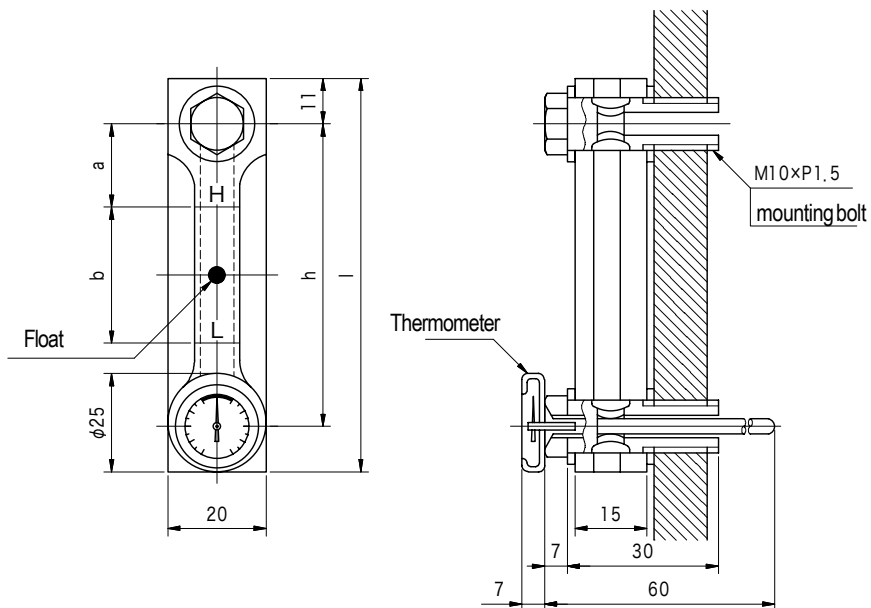

Dimensions

Model	l	h	a	b
OLG (T) 1-100	122	100	20	—
OLG (T) 1-200	222	200	30	—
OLG (T) 2-100	122	100	20	40
OLG (T) 2-200	222	200	30	60

# Minifan coolers MF



Functional Symbol

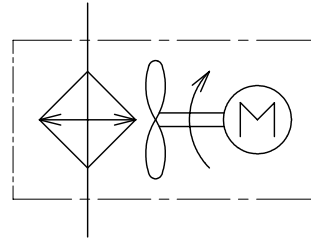

• Mini-fan coolers are principally used to cool drain lines of variable displacement pumps.

## Model Code

### MF-2 - 100V - 30 - 01

1 2 3 4 5

- |   |   |
|---|---|
| <p>1 Mini-fan cooler</p> <p>2 Series<br/>2:MF-2 Series<br/>3:MF-3 Series</p> <p>3 Fan motor voltage<br/>100V:AC100V 50/60Hz single phase<br/>200V:AC200V 50/60Hz single phase</p> | <p>4 Design no.<br/>30:MF-2 Series<br/>31:MF-3 Series<br/>32:Wall mounted type (for strength, applicable to MF-2, MF-3 Series)</p> <p>5 Control no.<br/>01:Standard<br/>02:Port position opposite of standard (applicable to MF-2 Series)</p> |
|---|---|

## Specifications

Model		MF-2	MF-3
Weight		3.5 kg	5.5 kg
Max. Operating Pressure		1 MPa	
Fan Motor	Type	Condenser motor	
	Electrical Specifications	100 V 50/60 Hz 50/48 W 0.62/0.52 A single phase	
		200 V 50/60 Hz 50/48 W 0.31/0.26 A single phase	
	Lead wire	With 0.5 mm <sup>2</sup> 2 core 1 m	



# Performance Curves (fluid ISO VG32)

## Heat Exchange Performance - Flow Characteristics

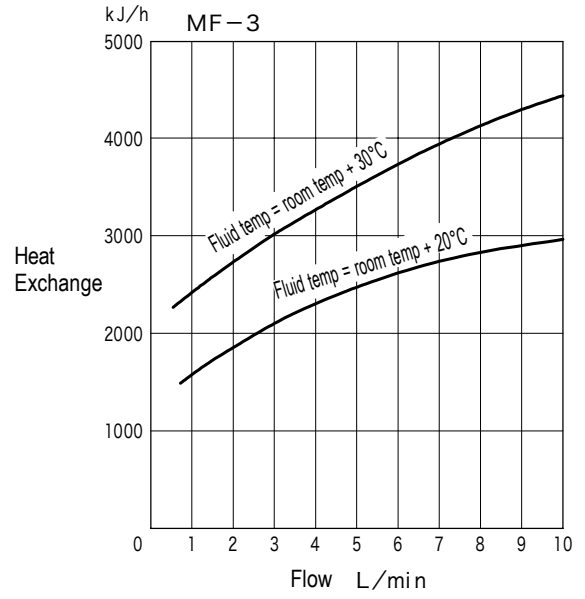
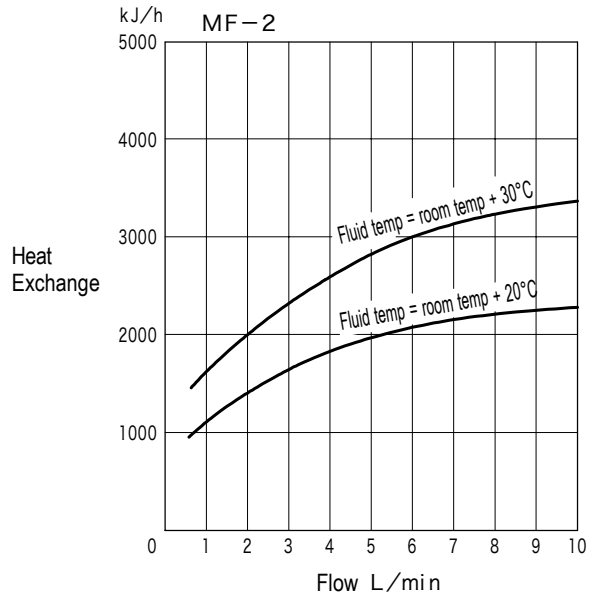

## Pressure Loss - Flow Characteristics

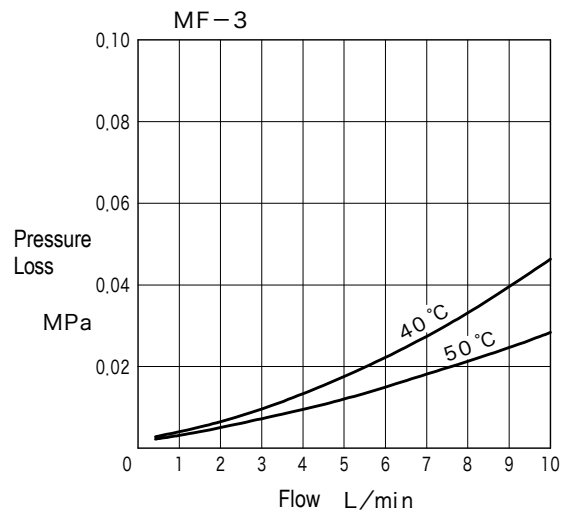
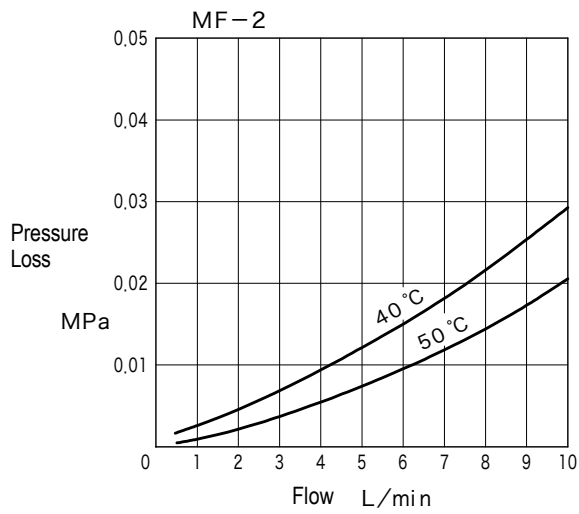

# Dimensions

MF-2-\*\*\*V-30/32-01/02

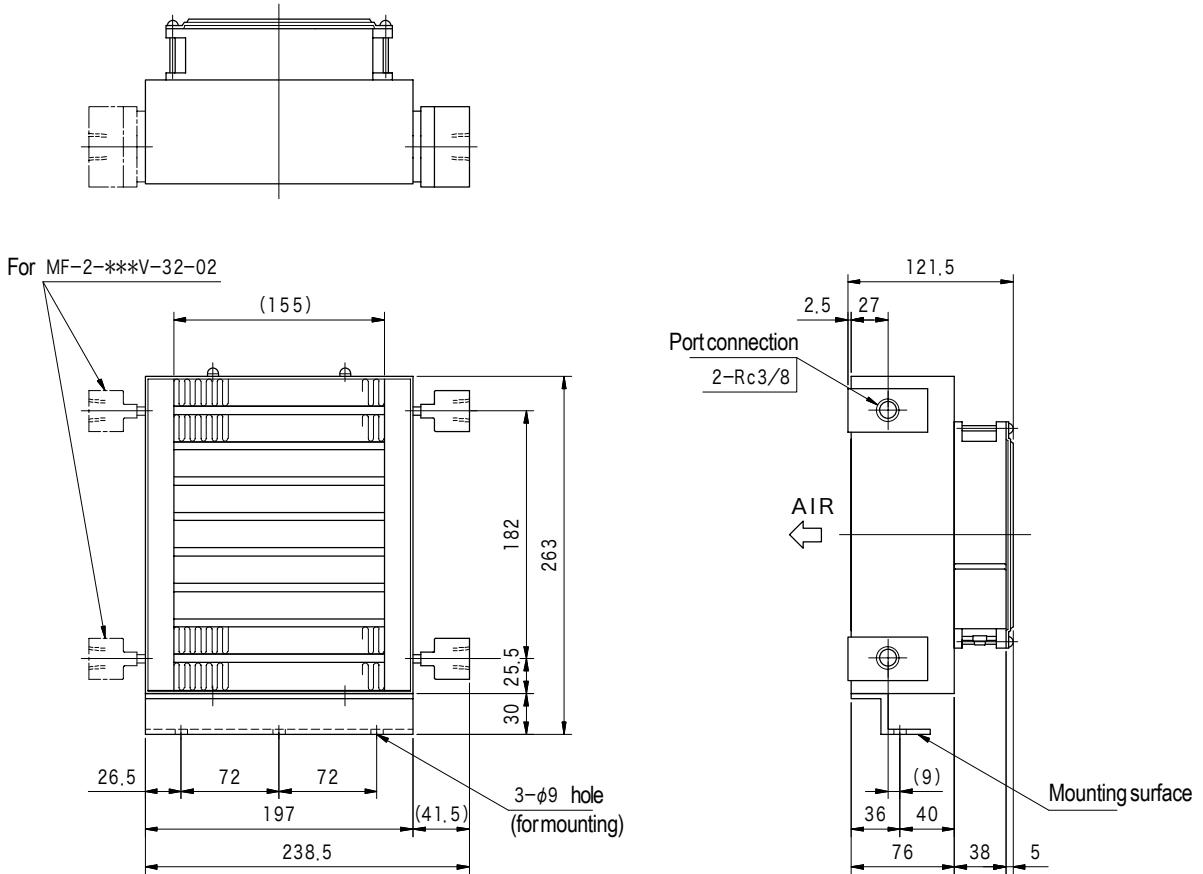

MF-3-\*\*\*V-31/32-01

